

NICE

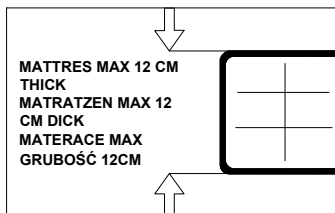

No.	Size [mm]	Pcs.	Package
1.1	450x40x40	4	2/2
1.2	845x40x40	4	2/2
1.3	1177x411	2	2/2
1.4	877x411	2	2/2
2	2000x411	1	1/2
3	2000x411	1	2/2
4	2000x411	2	1/2 + 2/2
5	995x27	8	1/2
6	895x53	17 slats (1x set)	1/2
7	600x53	17 slats (2x set)	2/2
8	985x95	2	1/2
9	365x95	3	1/2
10	2000x95	1	2/2

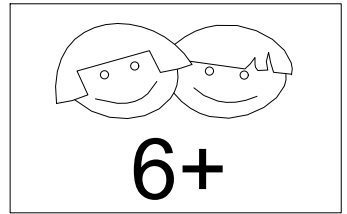
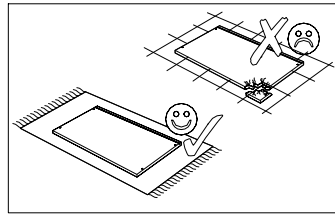
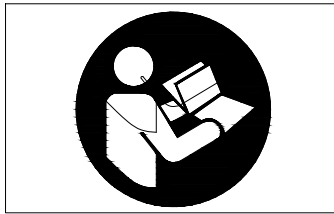
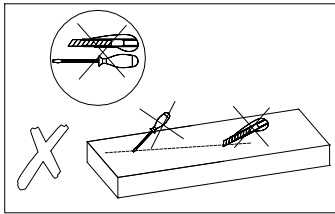
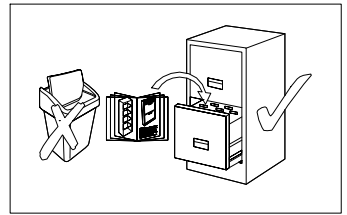
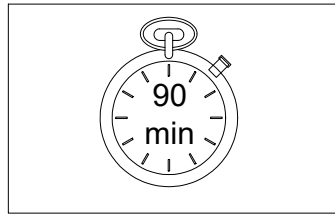
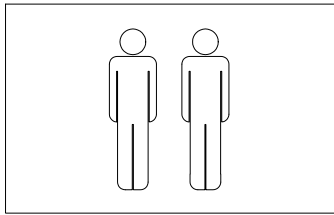
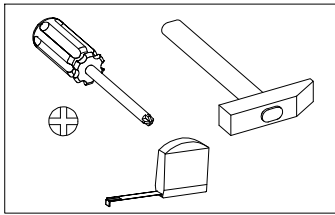
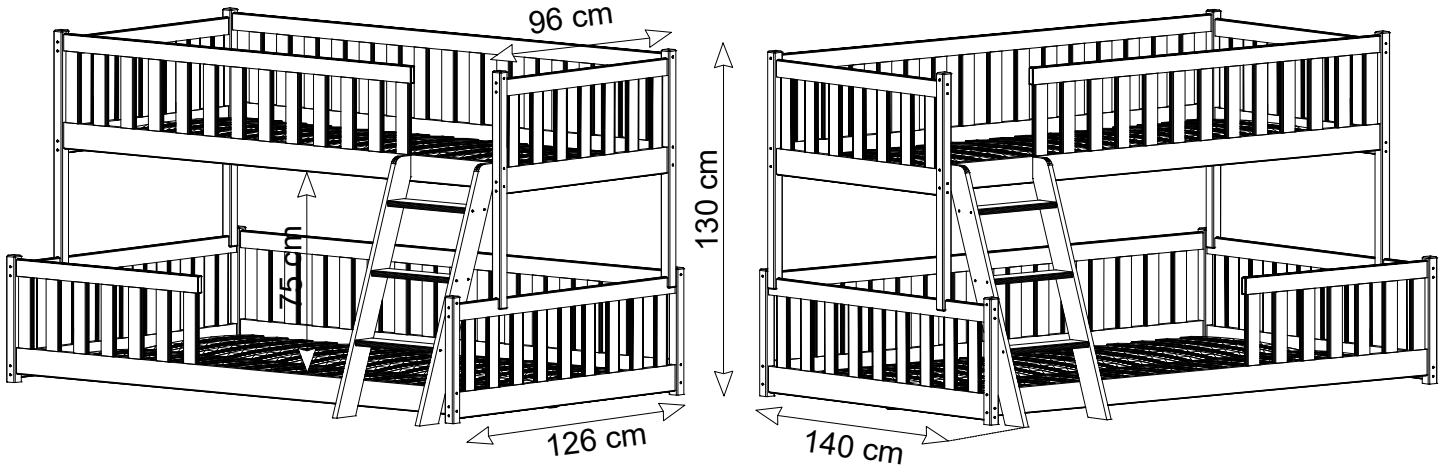
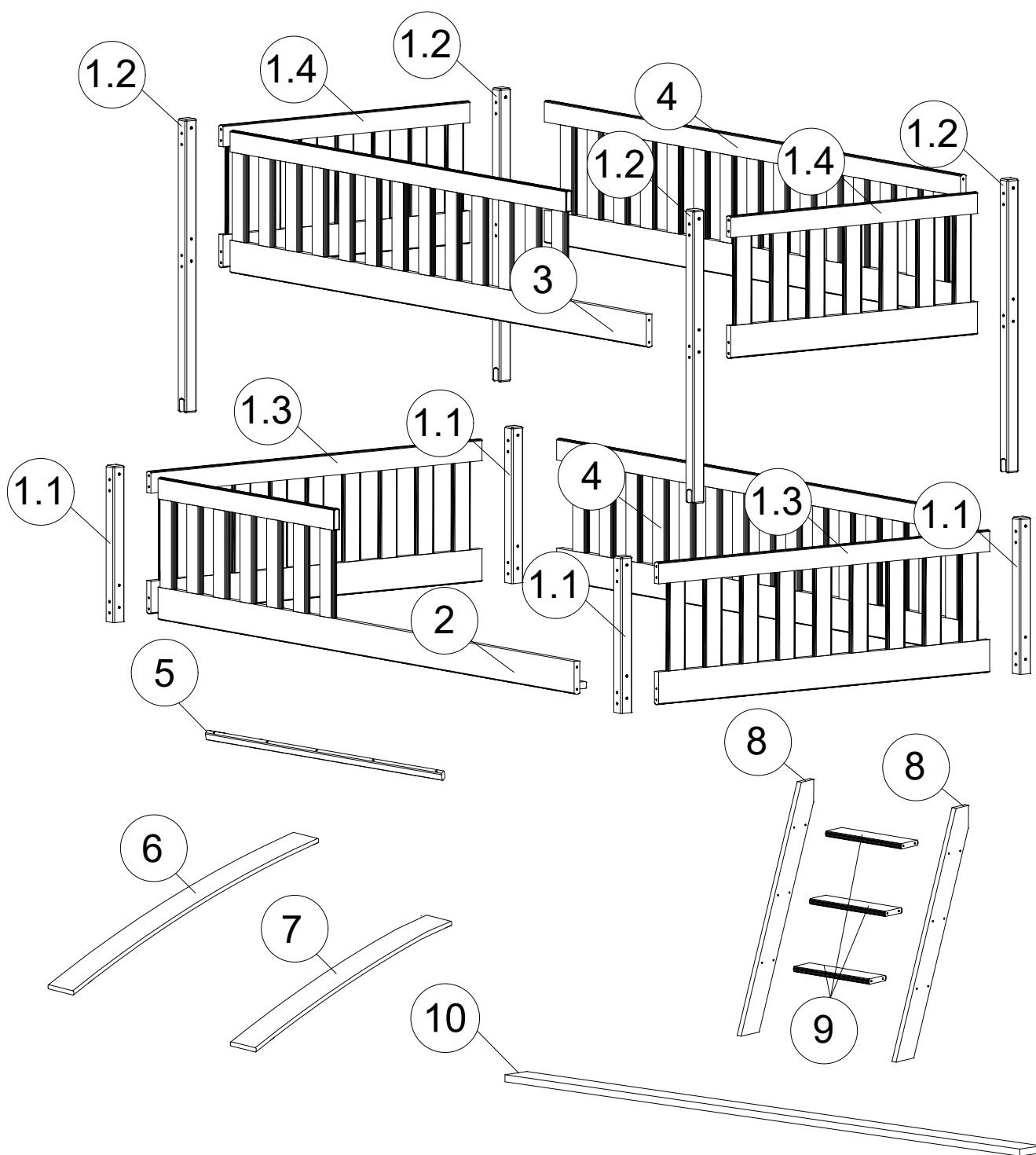

FITTINGS CHECKLIST

Ø3.5x25



D x 23

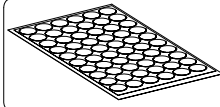

B x 1kpl

Ø4x40

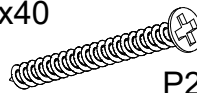

P2 x 42

Ø7x70

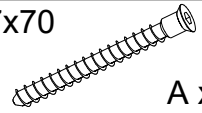

A x 54

Ø7x50

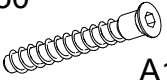

A1 x 12

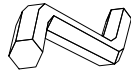

B x 1

H-45



x 5

1

Ø7x70

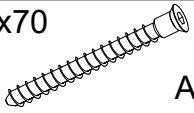

A x 16

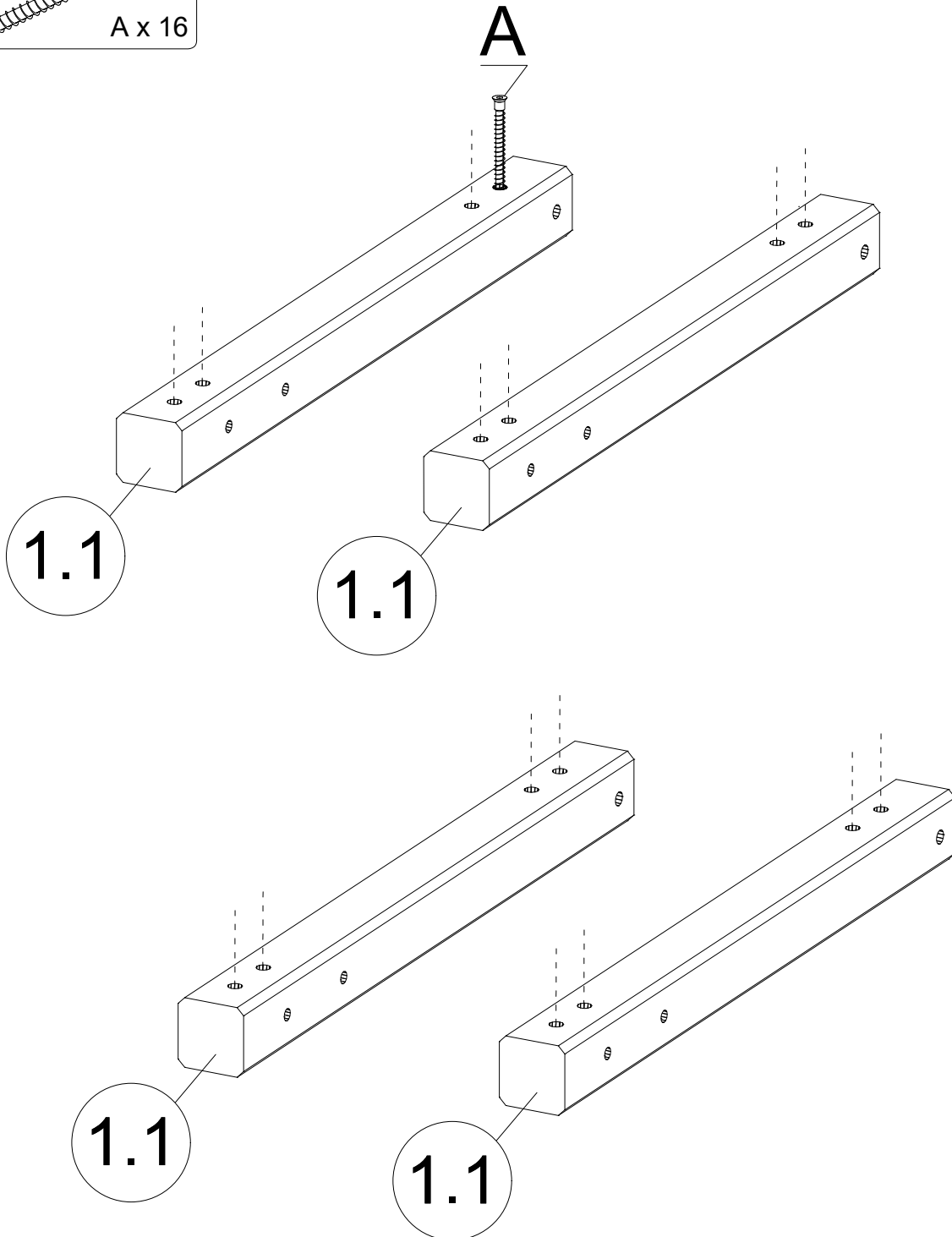

2

Ø7x70

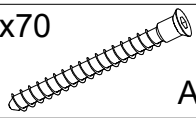

A x 16

A

1.2

1.2

1.2

1.2

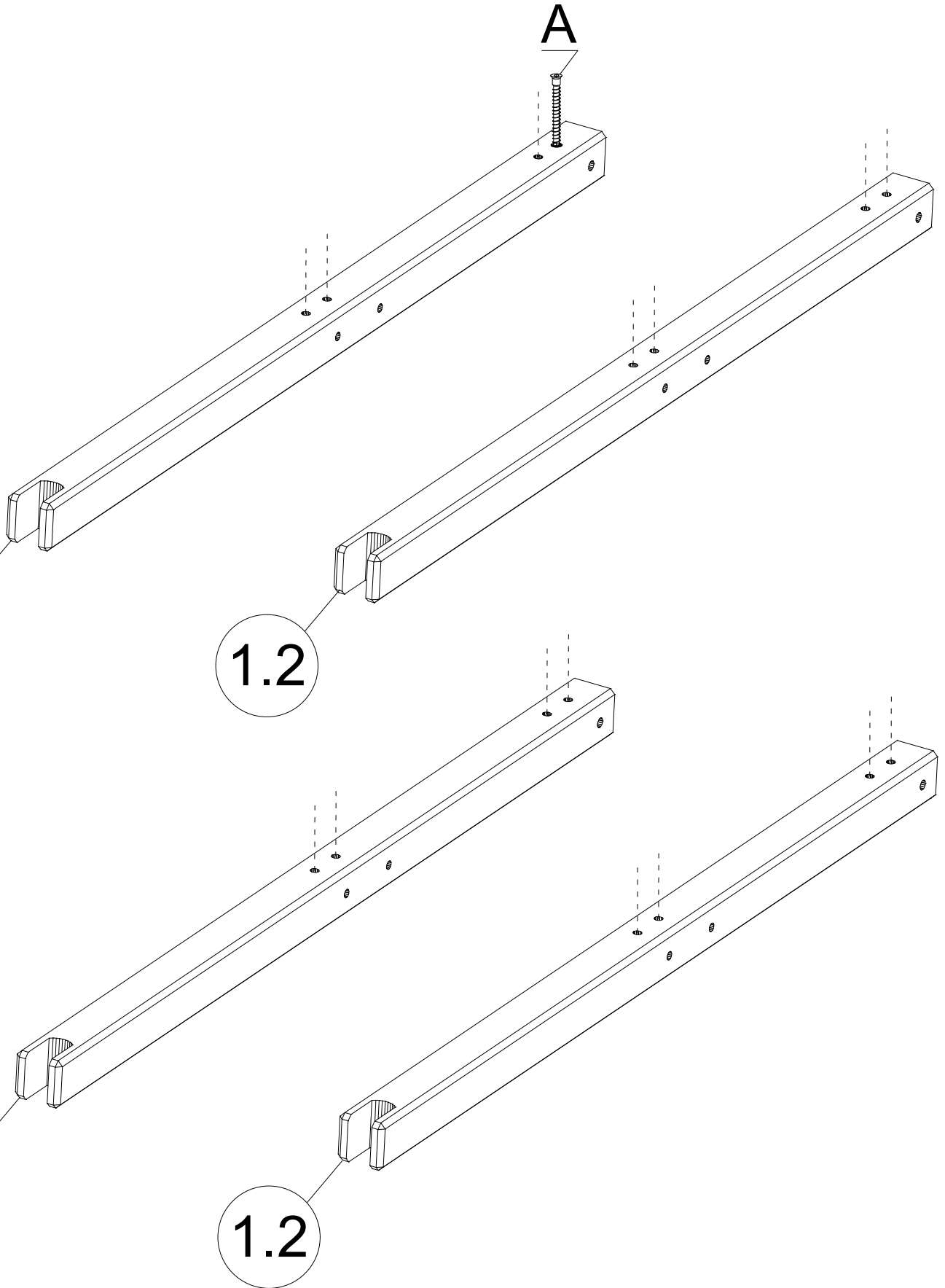

3

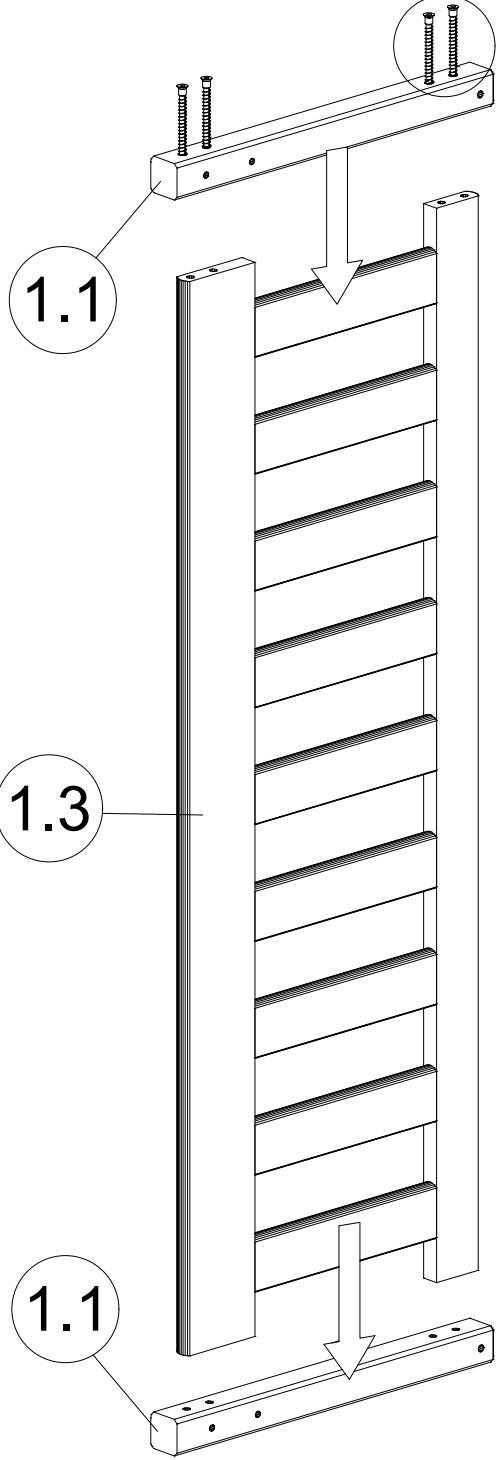
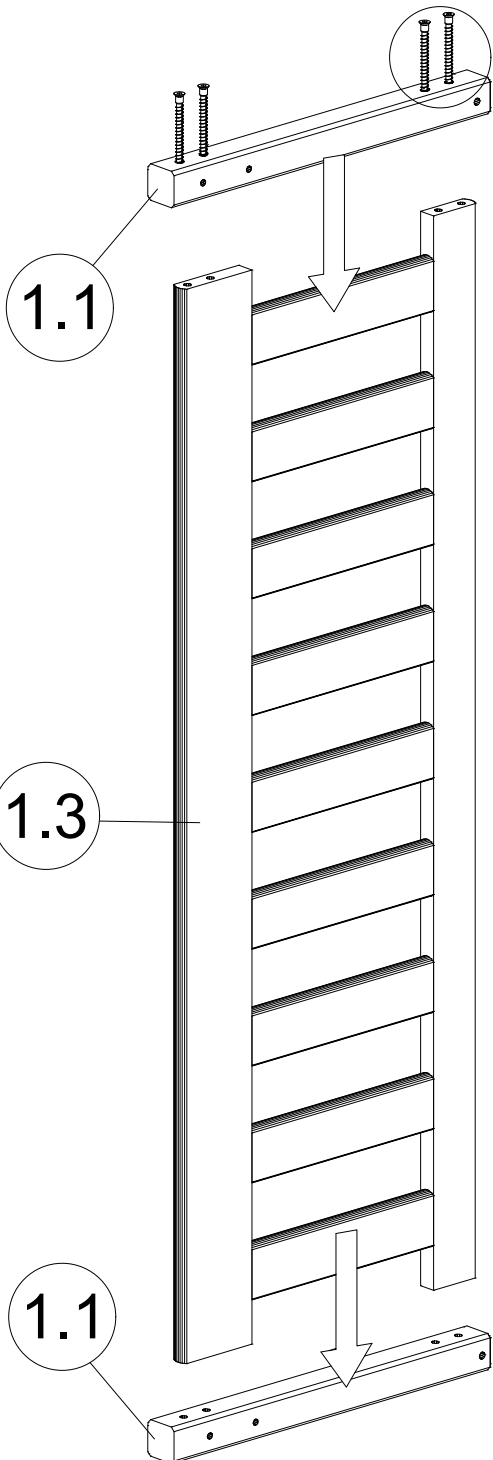
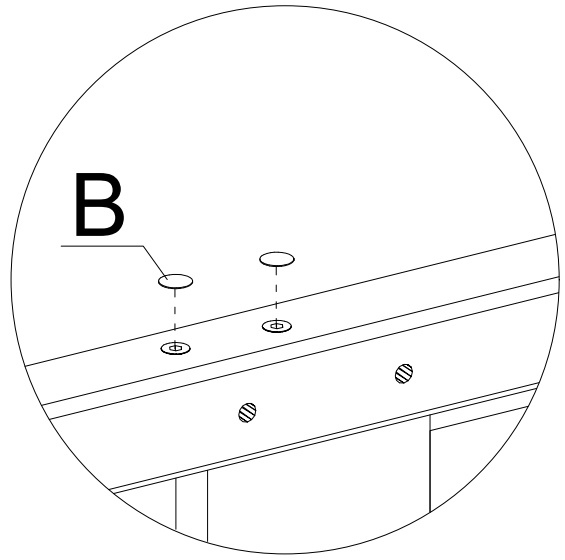
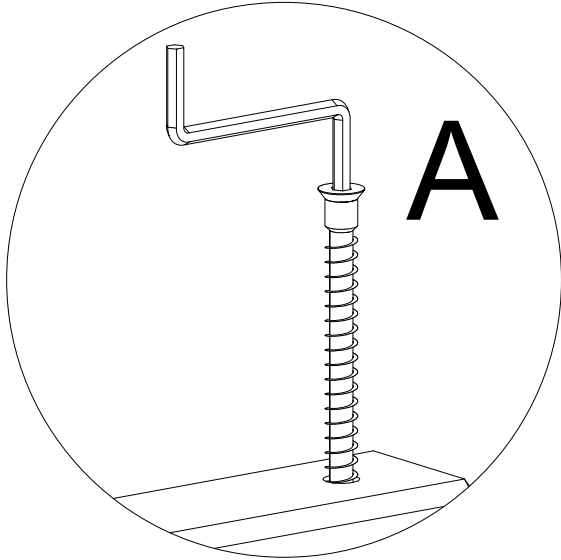
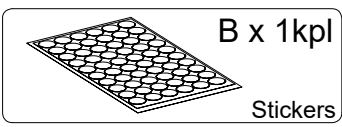

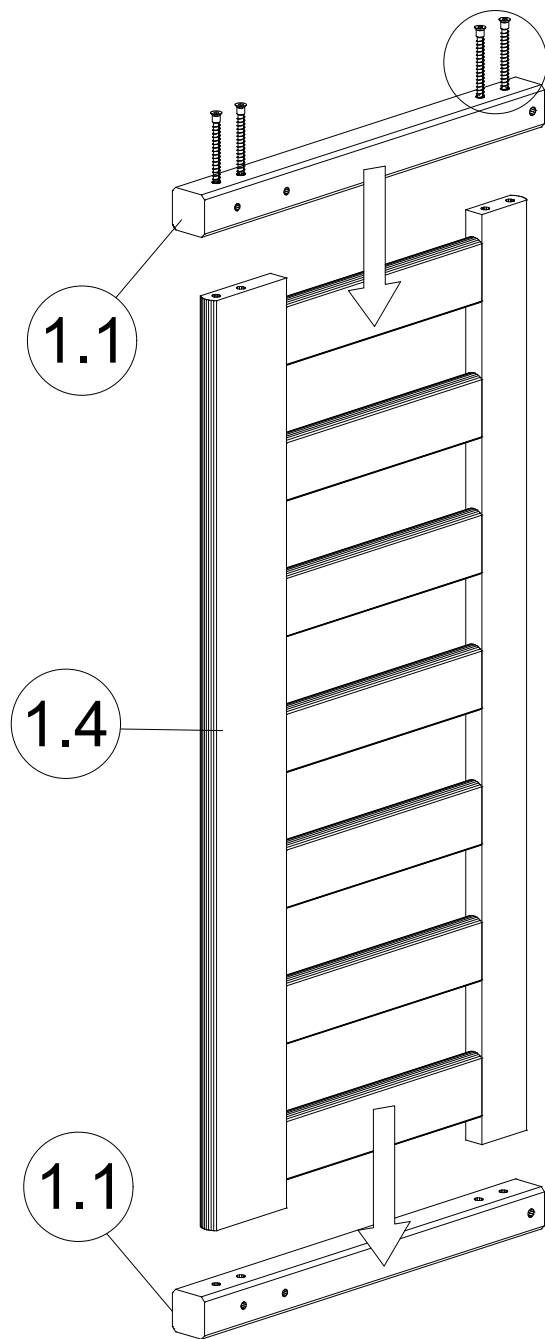
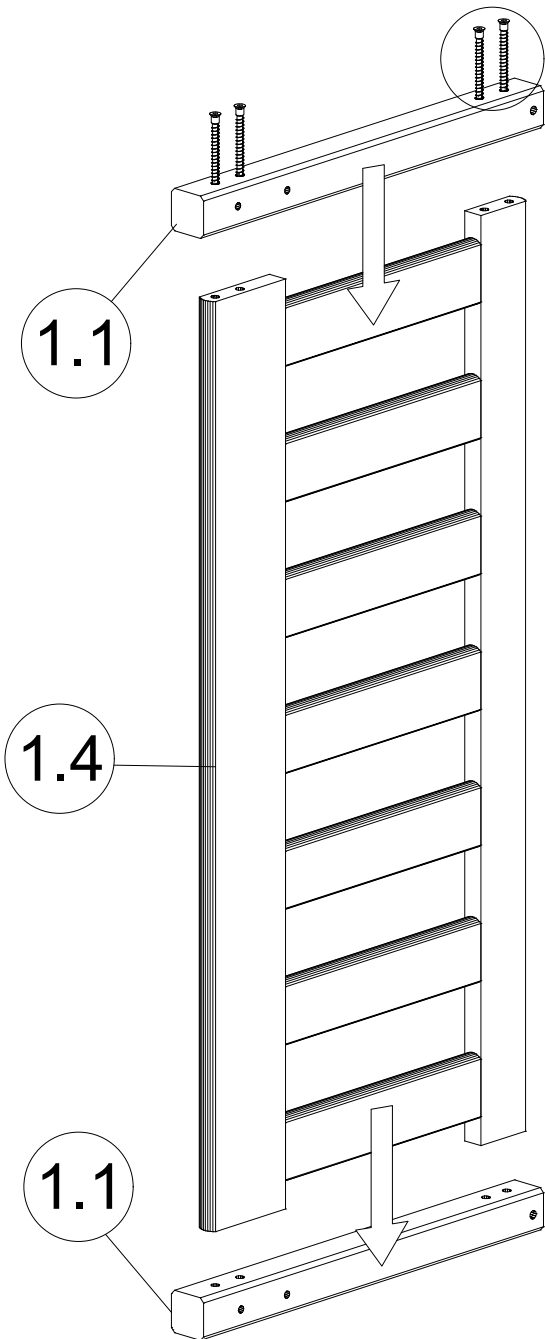
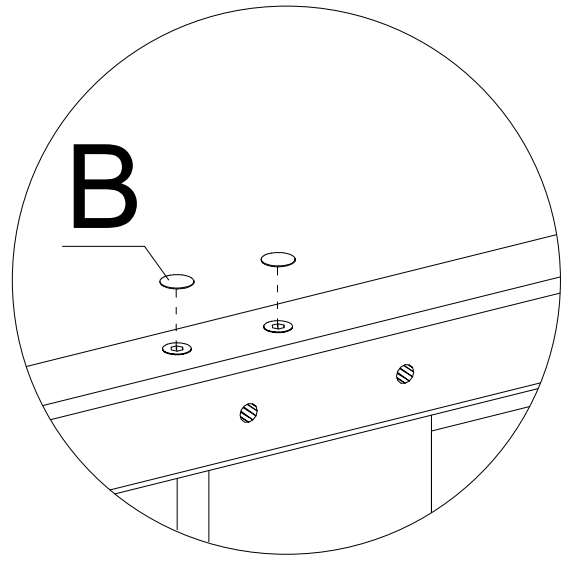
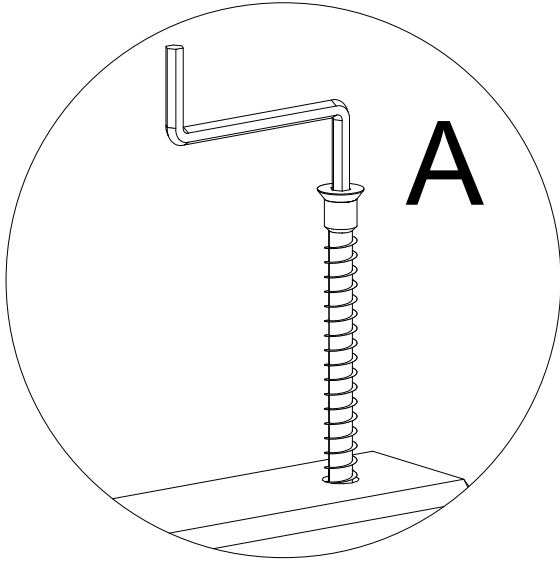
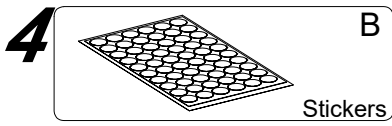

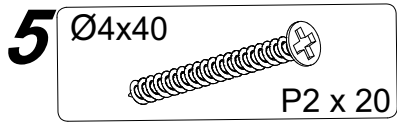

Einstieg rechts / Entry gap right /
Wejście po prawej stronie

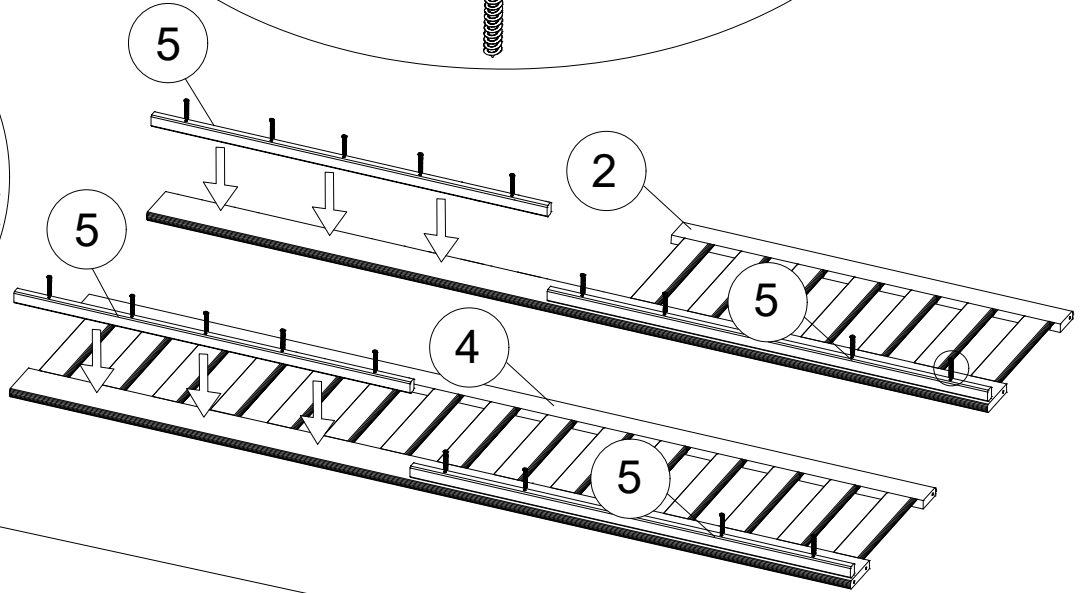
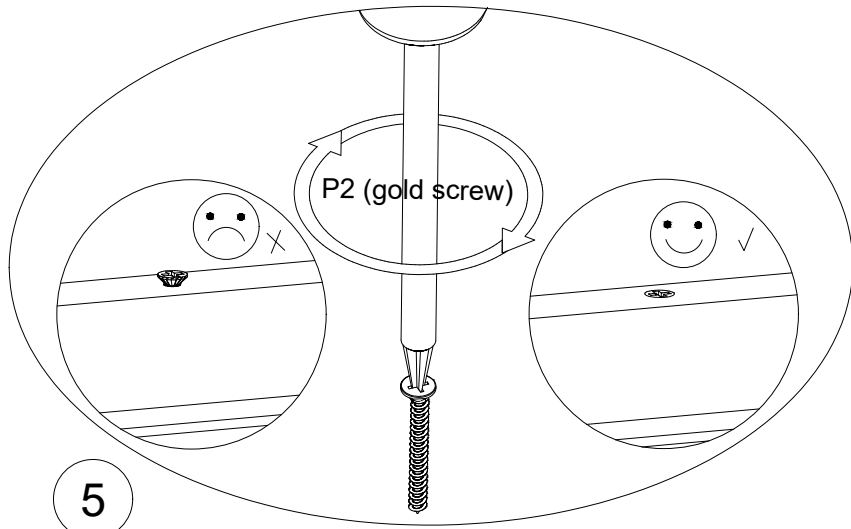
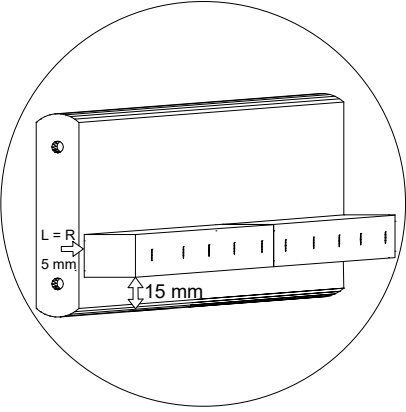
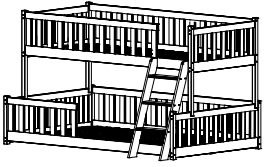

Einstieg links / Entry gap left /
Wejście po lewej stronie

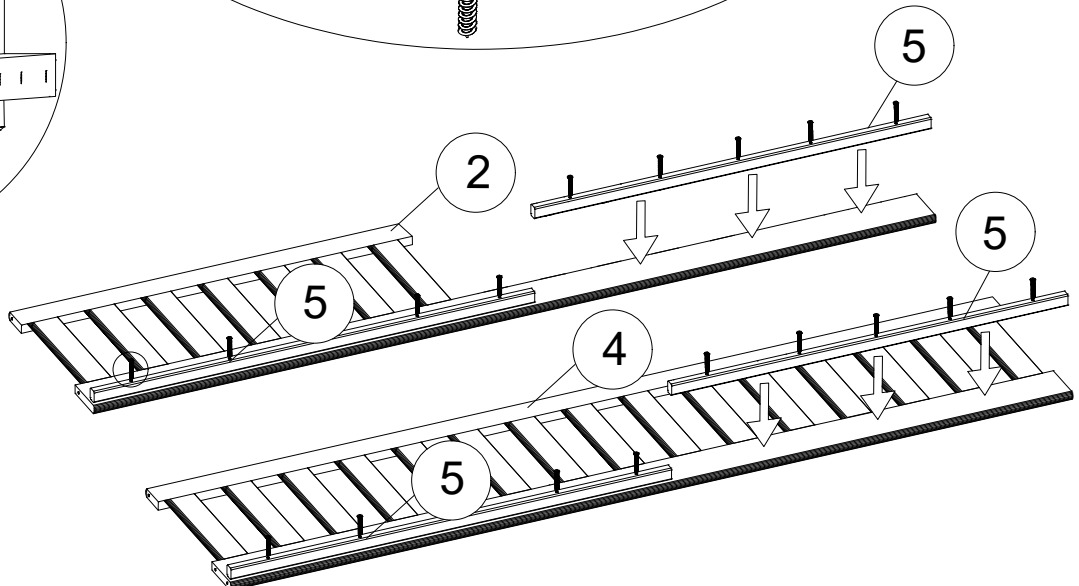
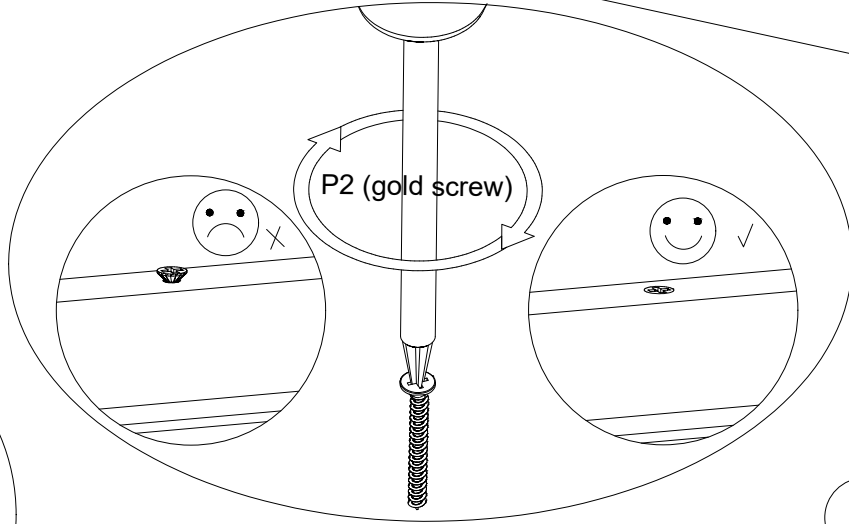
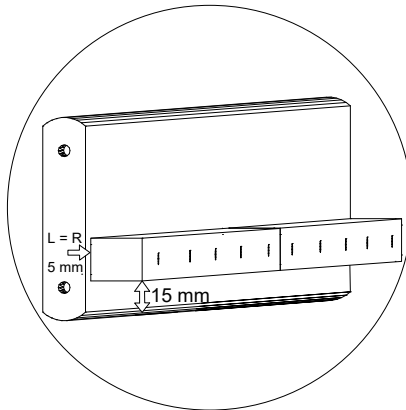

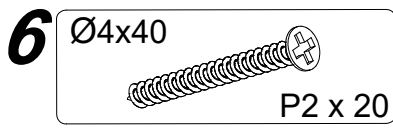

Einstieg rechts / Entry gap right /
Wejście po prawej stronie

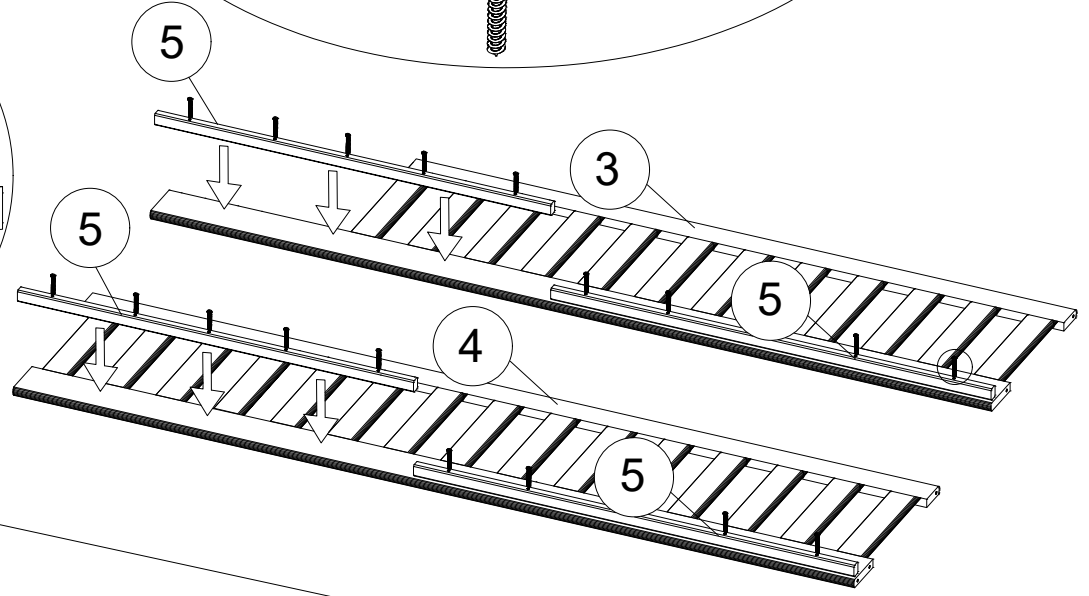
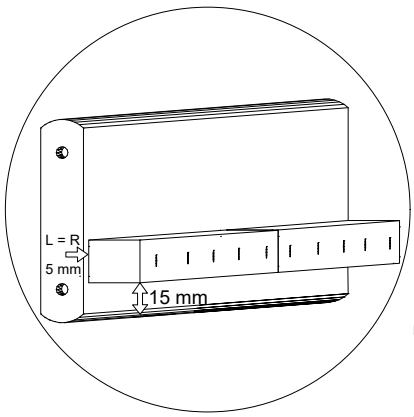
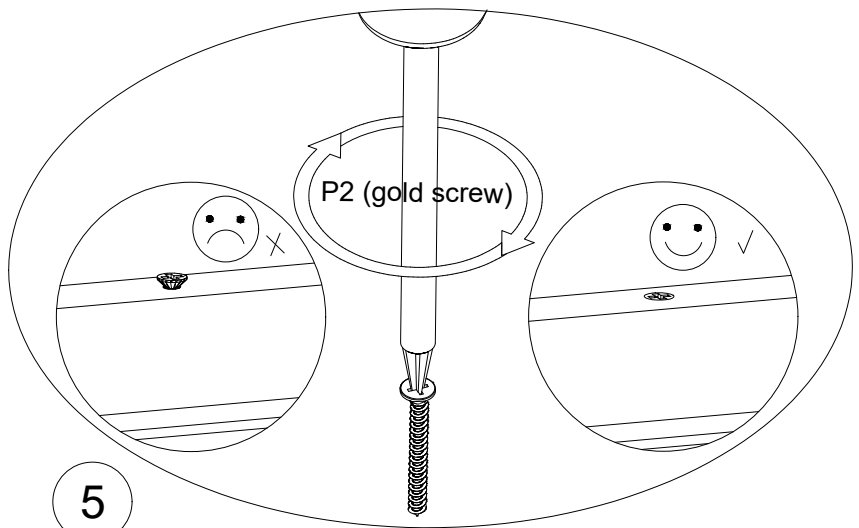
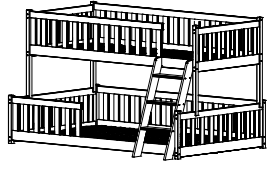

Einstieg links / Entry gap left /
Wejście po lewej stronie

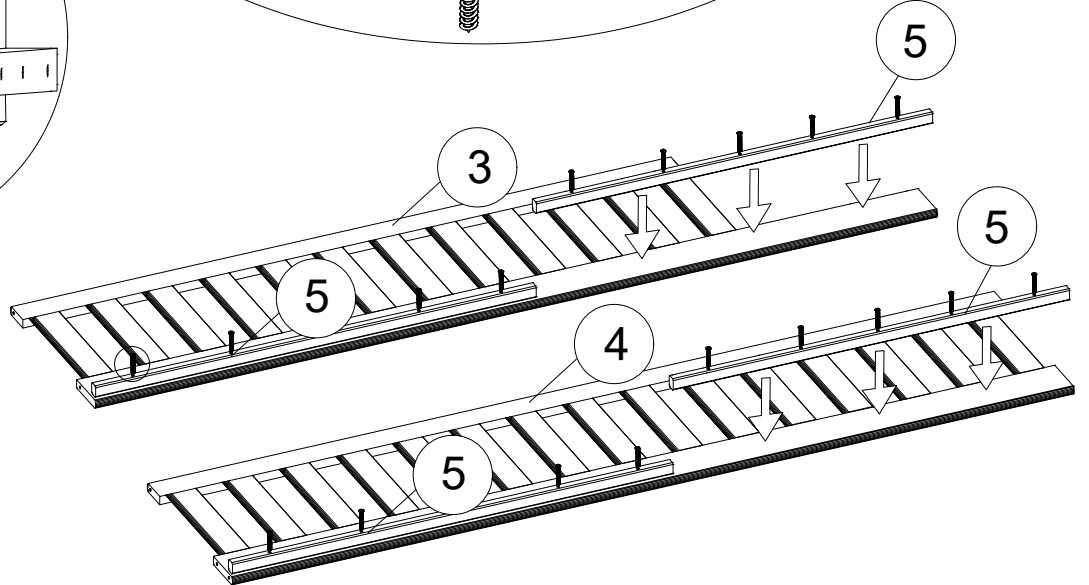
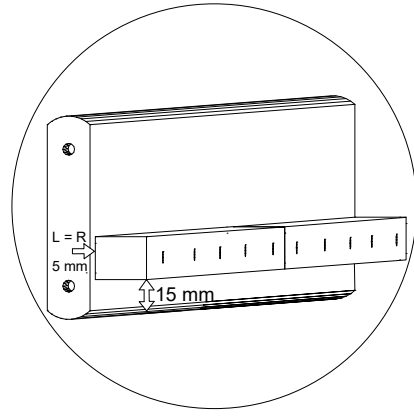
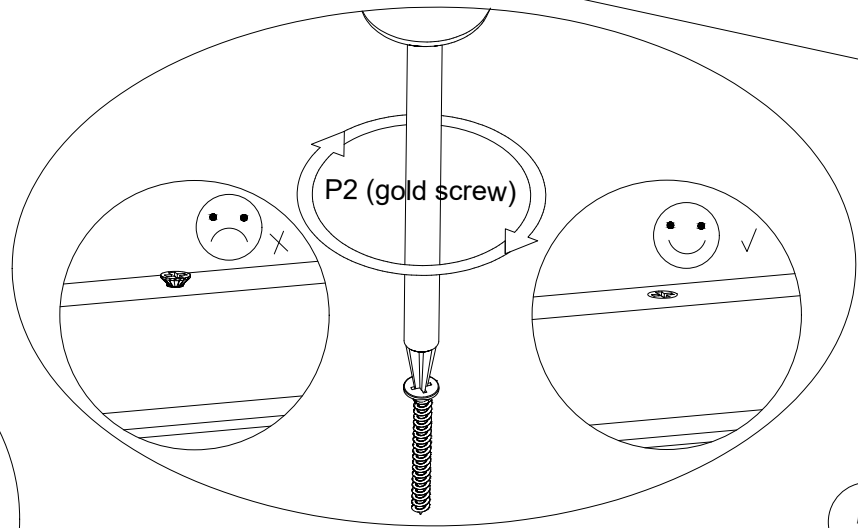
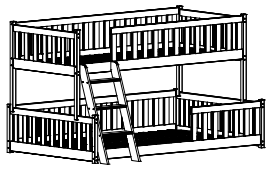

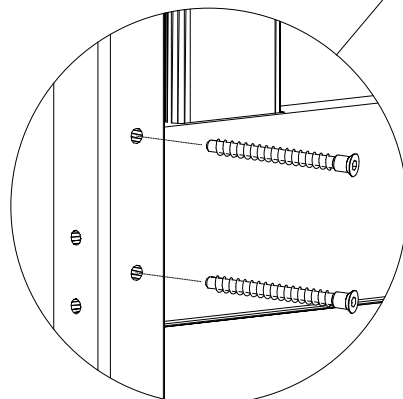
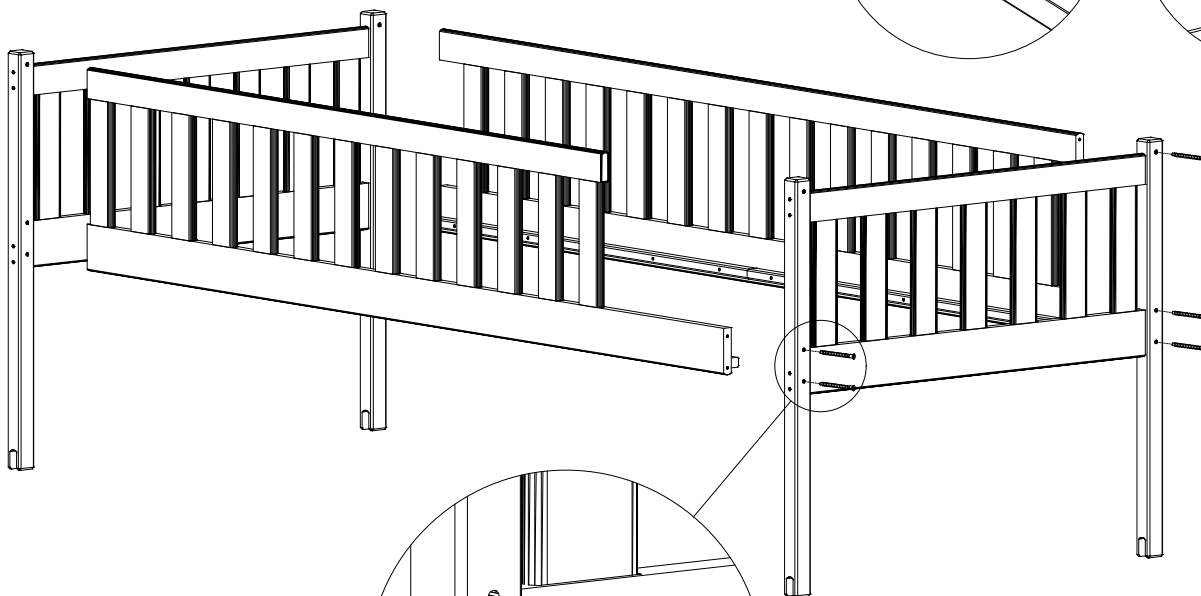
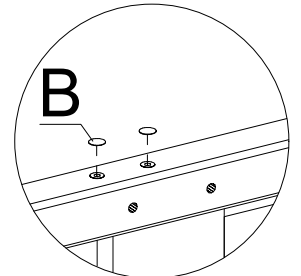
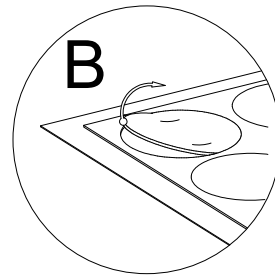
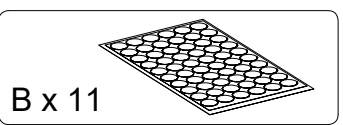
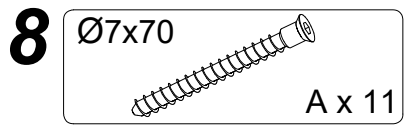
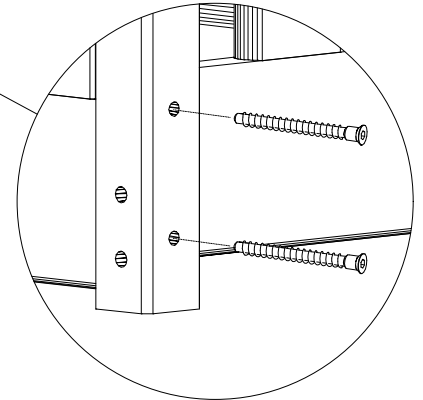
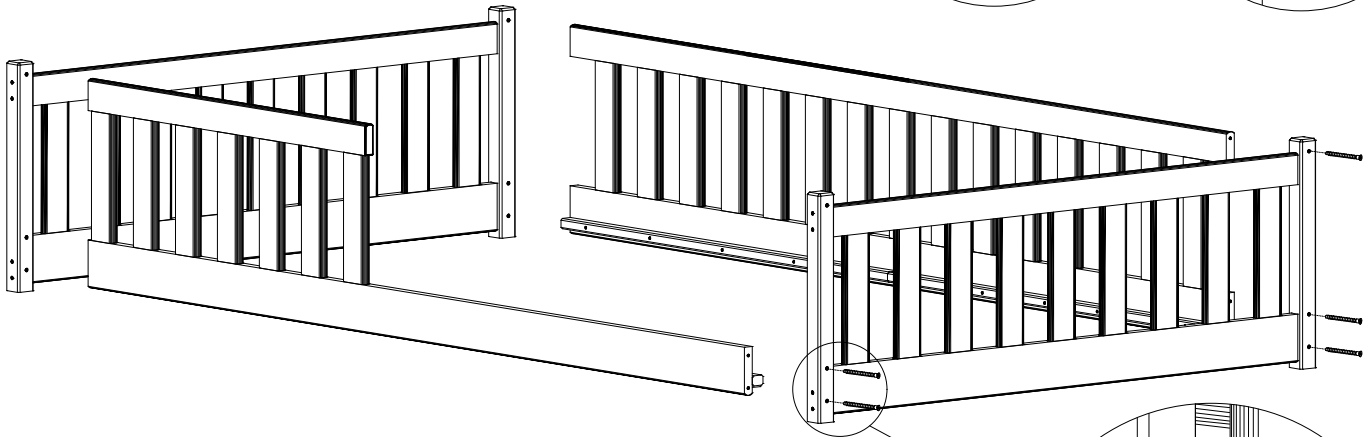
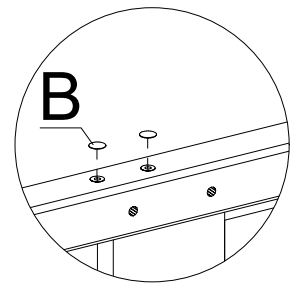
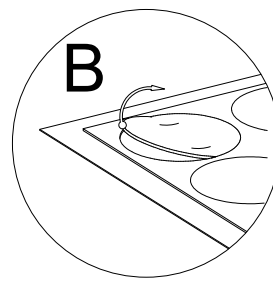
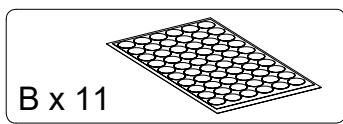
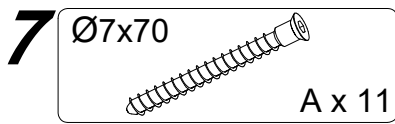

9

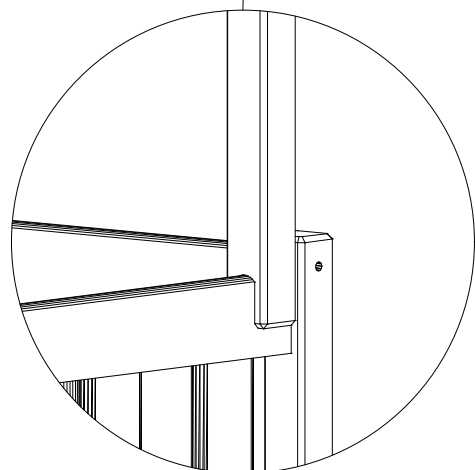
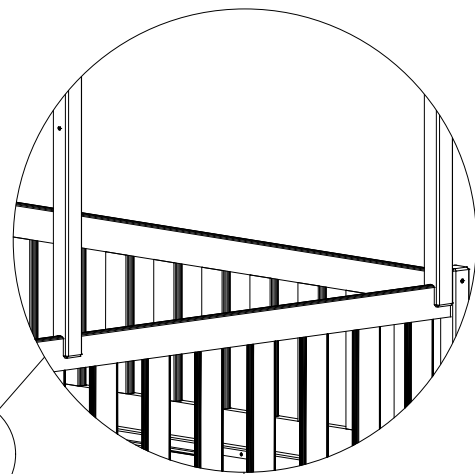
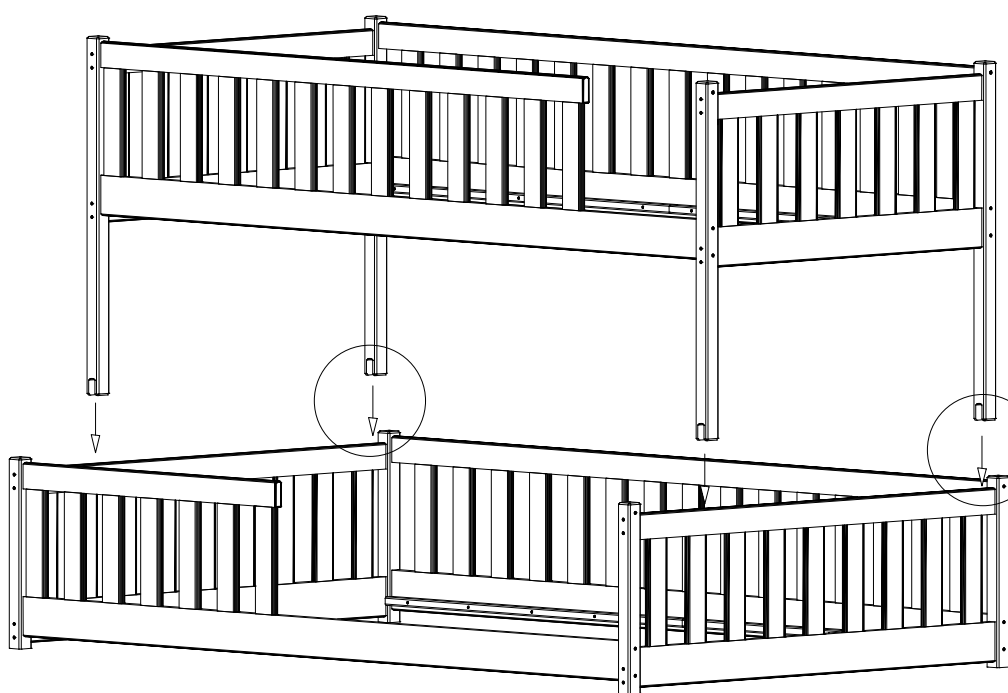

10

Ø7x50

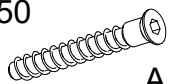

A1 x 12

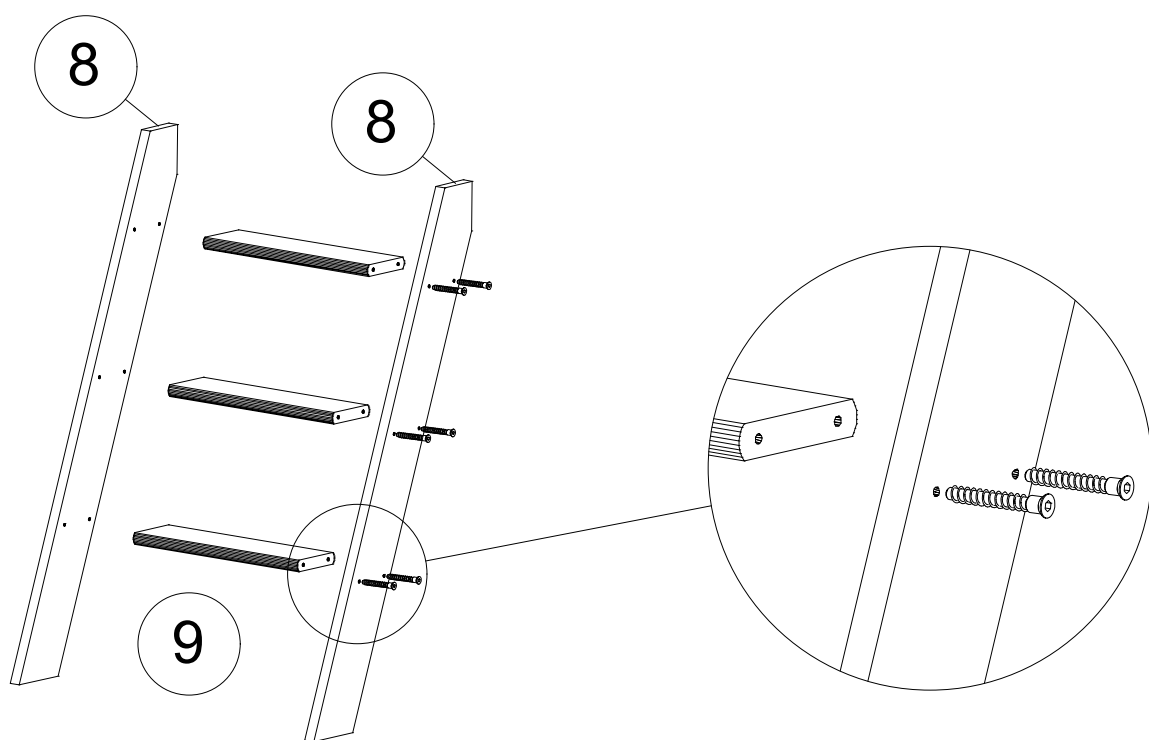

11

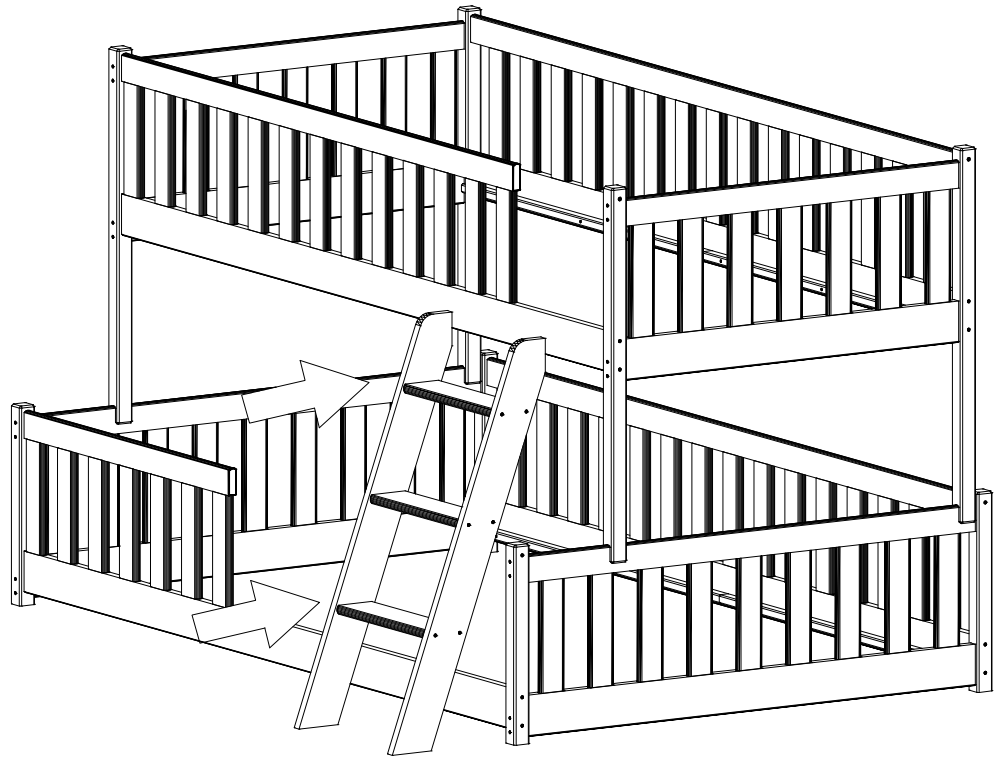
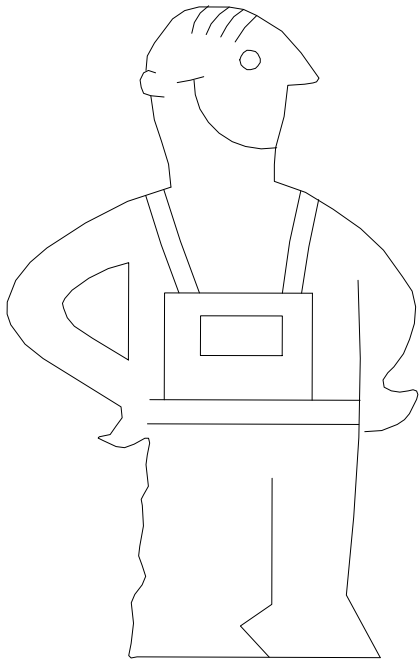

12

Ø4x40

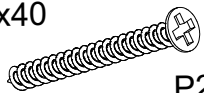

P2 x 2

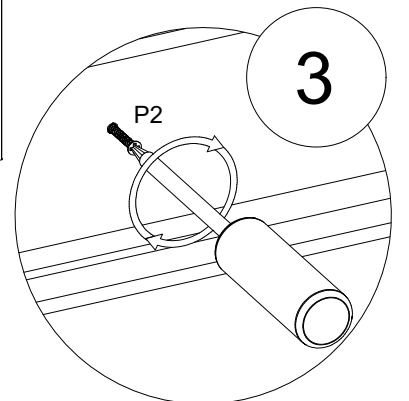
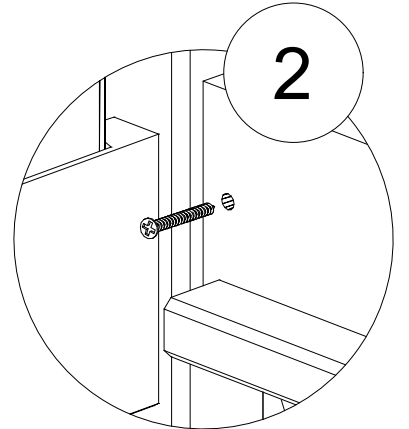
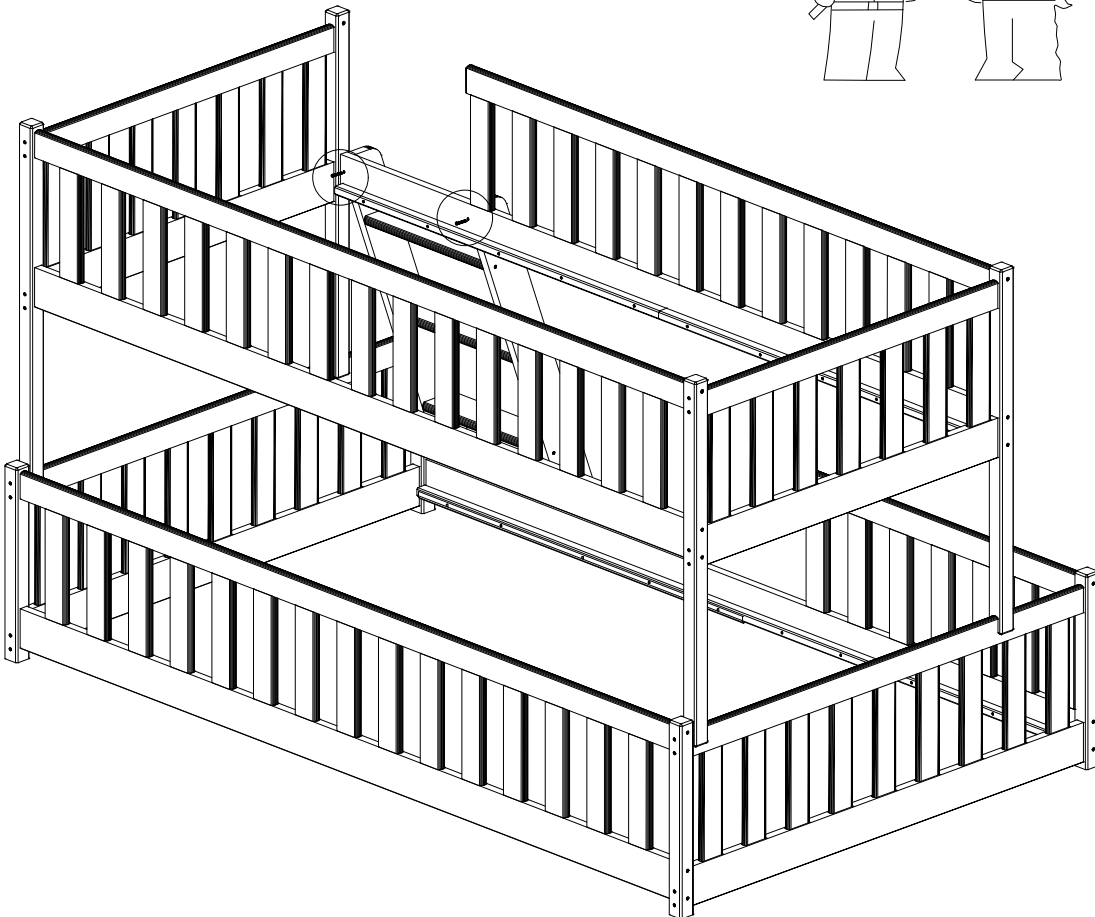
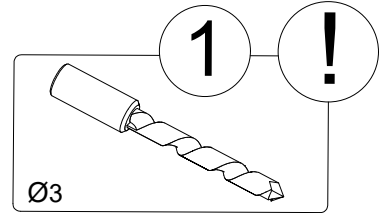
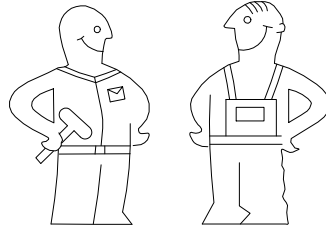

13

H-45



x 5

Ø3,5x25



D x 5

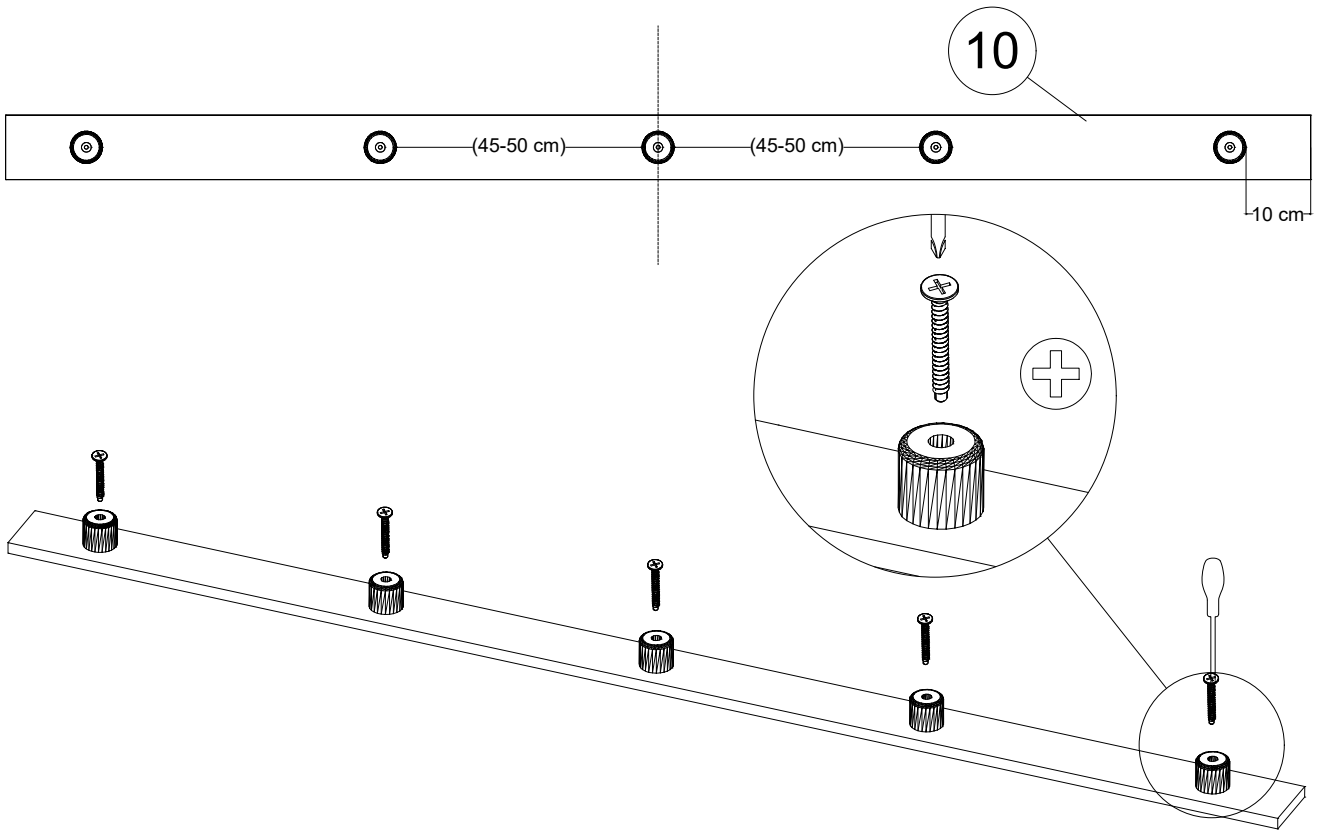

14

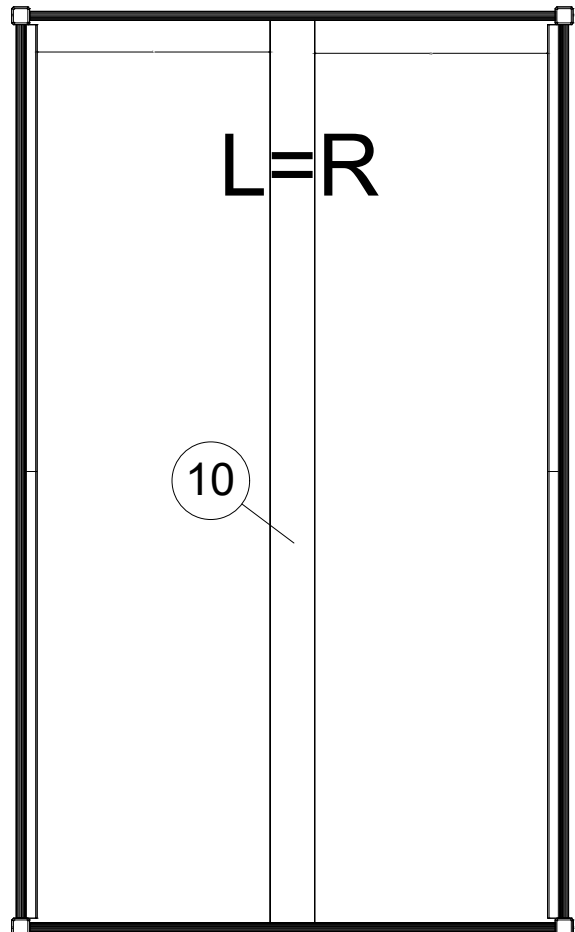
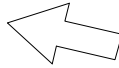
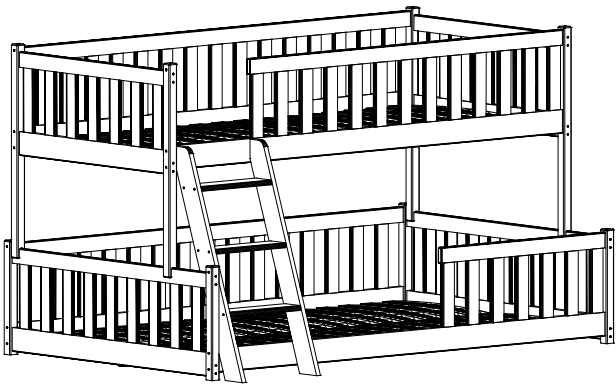

14

Ø3.5x25



D x 12

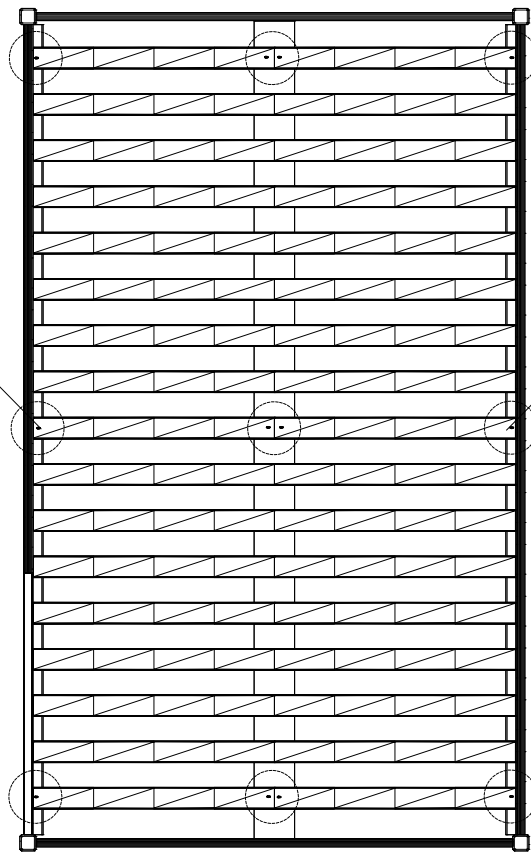

↑
Uwypukleniem do góry
Wölbung nach oben
Curved side up

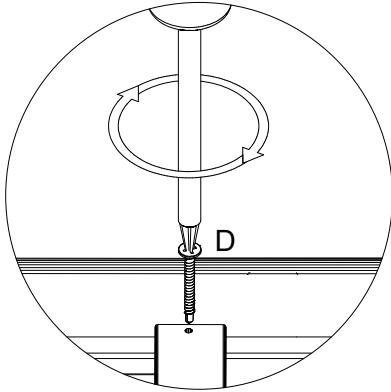

15

Ø3.5x25



D x 6

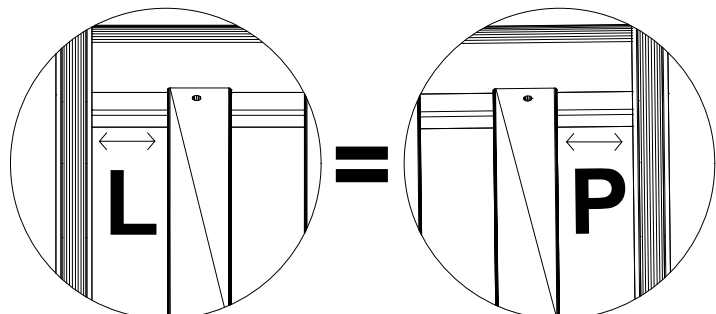
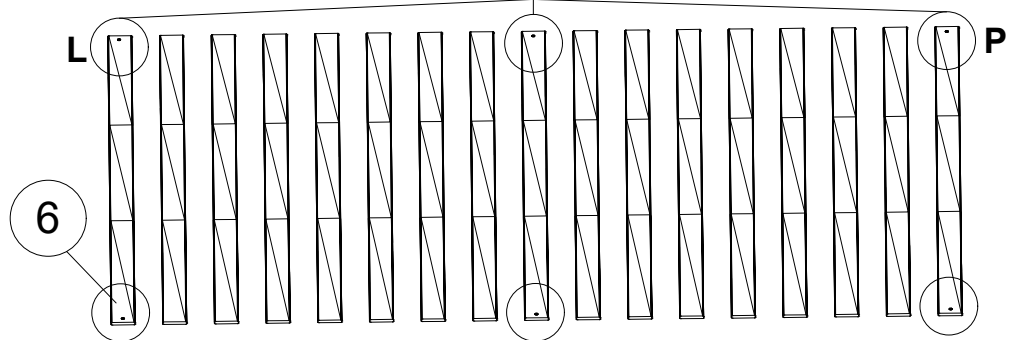
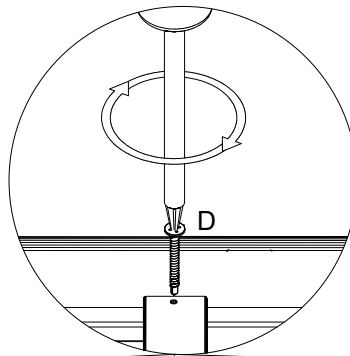
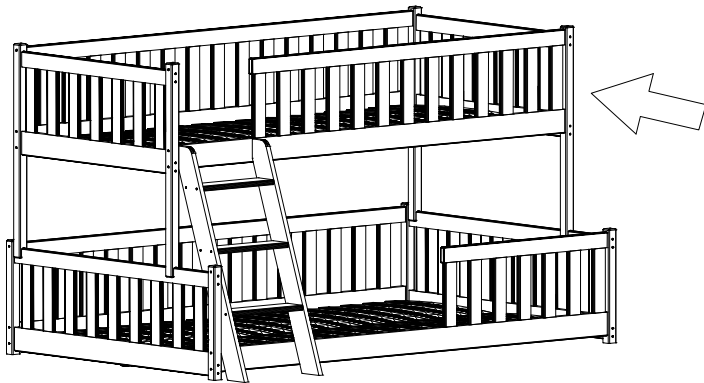

Mögliche Farb-Vergilbung: Holz ist ein Naturprodukt, dessen Maserung, Textur und Farbe wachstums-, standort- und klimabedingten Schwankungen unterworfen sind. Außerdem verändert sich der Farbton der Holzoberfläche mit der Zeit durch Licht und Wärme.

Alle Holzarten sind diesem natürlichen Alterungsprozess mehr oder weniger stark unterworfen. Holz ist nicht resistent gegen Licht. Sonnenlicht, auch diffuses Tageslicht in Innenräumen, trägt am meisten zur Farbveränderung bei. Der Grad der Farbveränderung hängt nicht nur von der Zeit ab, sondern auch vom Standort der Möbel.

Bitte drehen Sie alle Schrauben und Bolzen vorsichtig und langsam ein, um Holz-Brüche zu vermeiden. Schrauben Sie Beschläge nicht zu dicht an der Kante an!

ACHTUNG! Das Produkt kann nach der Montage bis zu 72 Stunden lang Geruch abgeben. Wischen Sie das Bett hierbei mit einem leicht feuchten Staubtuch ab.

There is a possibility of yellowing of the coating of white coloured beds.

Wood is a natural product, whose natural grain, texture and colour are subject to fluctuations associated with growth, location and climate. Moreover, hue of the wood surface varies over time as a result of light and heat.

This natural process of aging is subject to greater or lesser extent on all types of wood. Wood is not resistant to light. Sunlight as well as diffused light inside the room contribute the most to colour change. The degree of changes to the shade depends not only on the passing of time, but also on placement of the furniture.

Invisible elements such as slats, frame supporting the slats, bottoms of drawers, etc. are not painted as the rest of the bed.

All bolts and screws are to be screwed gently and slowly to avoid damaging the panels by cracks. Do not screw fittings close to the edges.

ATTENTION!

After assembling, please wipe the bed with a damp cloth. The product might give off a strong scent of paint after assembling, usually up to 72hours.

Możliwość żółknięcia powłoki koloru białego.

Drewno jest produktem naturalnym, którego usłojenie, struktura i kolor podlegają wahaniom związanym ze wzrostem, lokalizacją i klimatem. Co więcej odcień barwy powierzchni drewna zmienia się z biegiem czasu w wyniku działania światła i ciepła.

Temu naturalnemu procesowi starzenia się podlegają w mniejszym lub większym stopniu wszystkie rodzaje drewna. Drewno nie jest odporne na światło. Działanie światła słonecznego, także rozproszonego światła dziennego wewnątrz pomieszczeń, przyczynia się najbardziej do zmiany koloru. Stopień występującej zmiany odcienia barwy zależy nie tylko od upływającego czasu, lecz także od umiejscowienia mebli.

Elementy niewidoczne takie jak : np. stelaż, dna szuflad, deska podtrzymująca stelaż, itp. nie są malowane, tak jak pozostała część łóżka.

Wszelkie śruby, a także wkręty proszę wkręcać delikatnie i powoli, w celu uniknięcia pęknięć.

NIE WKREĆCAĆ okuć blisko krawędzi ! (DOTCZY GŁÓWNIE SZUFLAD).

UWAGA ! Produkt może wydzielać zapach po złożeniu , do 72 godzin